

BIRO

Our Equipment Works Harder So You Don't Have To

Increase your yield and make a better product with the Biro Model VTS-100 Vacuum Tumbler. The heavy duty casters let you do your tumbling anywhere in your plant, and the drain hole in the drum makes cleanup a snap. Run/jog controls let you position the drum for easy cleaning or unloading, and a lug on a cart fits nicely under the drum for easy unloading. Of course, we've made sure that the new Biro Model VTS-100 has a vacuum pump that can evacuate the drum quickly, so you don't have to sit around and wait. All of this means that the Biro Model VTS-100 works harder so you don't have to.



EXTERNAL MOISTURE TRAP
NOT SHOWN

VTS-100



**Stands alone for quality
and value since 1921**

SPECIFICATIONS

MODEL VTS-100 VACUUM MARINATING TUMBLER.
ELECTRICAL 3/4HP, 115 VOLTS, 60 CYCLE, 1 PHASE.
 8' CORD AND PLUG, CONTROLS NEMA 4X RATED
CONSTRUCTION STAINLESS STEEL DRUM AND FRAME.
MOTORS

CONTROLS ARE NEMA 4X RATED

MOTOR	HP	TYPE	KW	VOLTS	AMPS	HERTZ	PHASE	CODE
DRIVE	¾	TEFC	.56	115/230	12/6	60	1	STD
PUMP	¾	OPDP	.56	115/230	12/6	60	1	STD
DRIVE	¾	TEFC	.56	220	7	50	1	EC
PUMP	¾	OPDP	.56	220	7	50	1	EC

STD=STANDARD OP=OPTIONAL EC=EXTRA COST
 TEFC= TOTALLY ENCLOSED FAN COOLED OPDP=OPEN DRIP PROOF

DRUM CAPACITY 100 LBS. (45.4 KG) APPROXIMATE.
DUMP HEIGHT 30" (762 MM), DRUM OPENING AT 9 O' CLOCK POSITION.
DRIVE MOTOR 3/4 HP (.56 KW).
 VARIABLE SPEED (0-14 RPM).
 60:1 TRANSMISSION
 TEFC (TOTALLY ENCLOSED FAN COOLED).
VACUUM PUMP 3/4HP (.56 KW) 60 CYCLE, 1 PHASE.
TIMER 0-50 MINUTE INTERVAL MODE TIMER.
TUMBLE SPEED 0-14 RPM.
SAFETY STANDARD PHOTO ELECTRIC EYE FOR SAFETY SHUT DOWN.
STANDARD FEATURES 5" LOCKING SWIVEL CASTERS, DRAIN CAP WRENCH,
 EXTERNAL MOISTURE TRAP WITH REMOVAL TOOL, INTERNAL IN-LINE FILTER,
 3 EXTRA FILTER ELEMENTS, 8' CORD AND PLUG 115V, 8' CORD NO PLUG 220 V, 4 ADJUSTABLE
 QUICK RELEASE TOGGLE CLAMPS ON LID, SILICONE LID GASKET, OPERATING AND SAFETY MANUAL.
OPTIONS (EC) 220-50-1 OR 220-60-1, LEG EXTENSIONS, STAINLESS STEEL LOCKING SWIVEL
 CASTERS AND BALL BEARINGS. REVERSE SWITCH MOMENTARY, PROGRAMMABLE REPEAT
 CYCLE TIMER (RUN-STOP-RUN) WITH TIME INHIBITOR (MEMORY), STAINLESS STEEL CRIMPED
 FITTINGS ON HOSE, 1 HP CONTINUOUS DUTY VACUUM PUMP.
CERTIFICATION U.L.
WEIGHT UNCRATED: 435 LBS. (198 KG).
 CRATED: 640 LBS. (290 KG).
DIMENSIONS CRATED L = 41" (1041 MM) X W = 62" (1575 MM) X H = 53" (1346 MM).

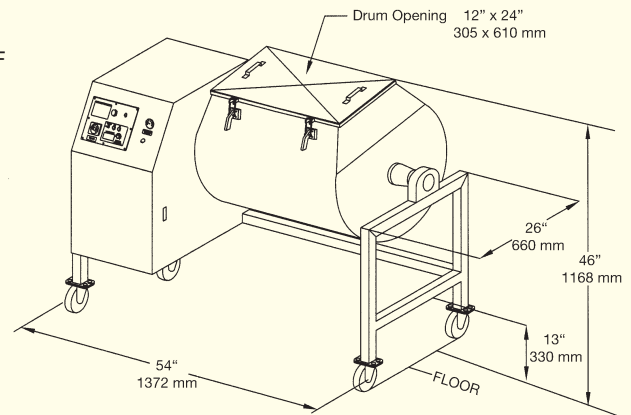

THE BIRO MANUFACTURING COMPANY
 1114 WEST MAIN STREET
 MARBLEHEAD, OH 43440-2099 U.S.A.
 Phone: (419) 798-4451
 Fax: (419) 798-9106
<http://www.birosaw.com>
sales@birosaw.com

ALL SPECIFICATIONS CONTAINED HEREIN ARE SUBJECT TO CHANGE WITHOUT NOTIFICATION.

ITEM NO.: LIT VTS-100-328
 FORM NO.: Md VTS-100-328-9-06-2-ENG-MARK

Service is available from over 245 locations worldwide